

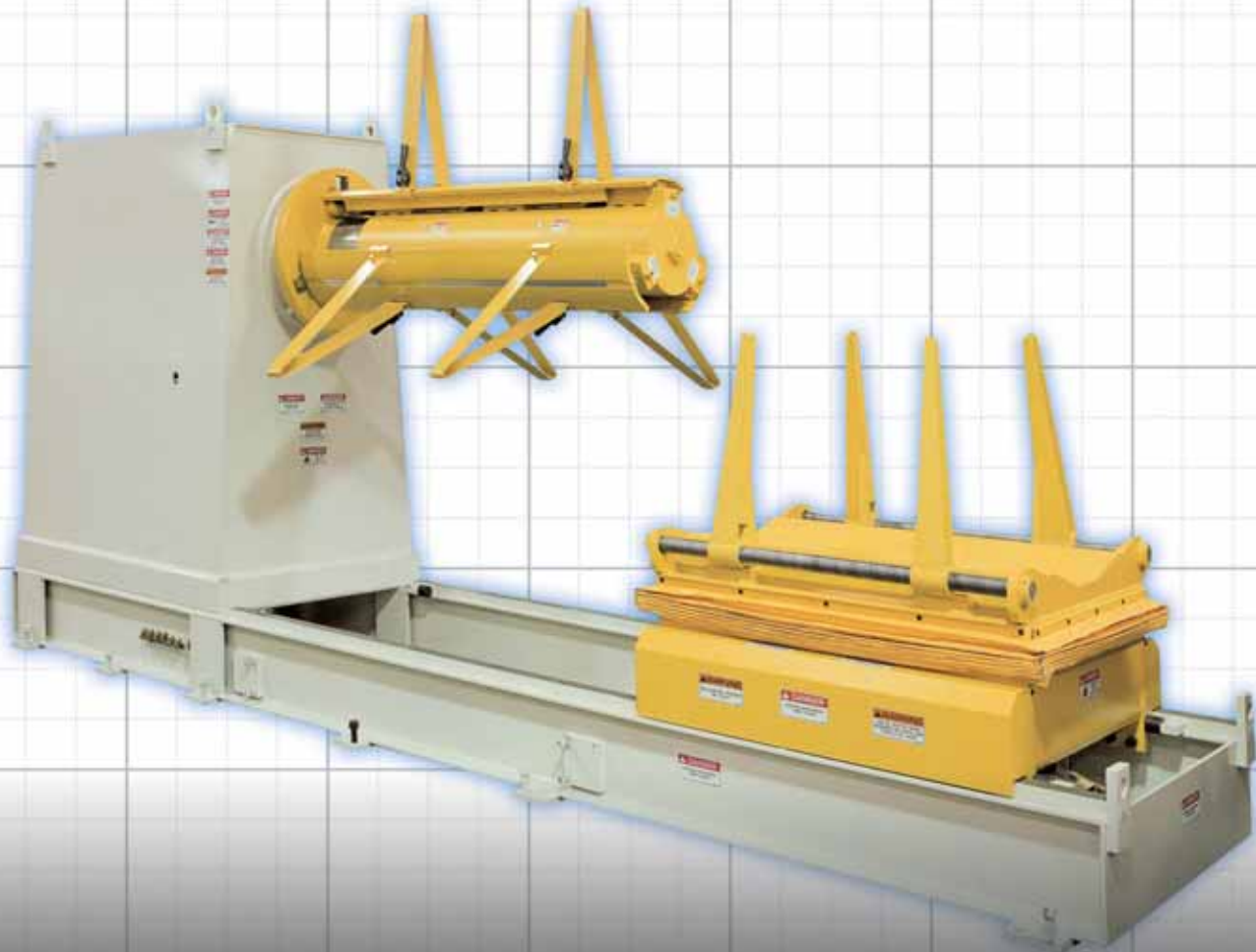

Coe Press Equipment Corporation

Coil Reels



Coe Press Equipment Corporation
"The Company That Feeds an Industry"

COIL REELS

■ **2,500# / 4,000# Series Reels**

Coil Capacity	Minimum Width	Maximum Width
2,500#	12"	36"
4,000#	18"	36"

Coe Press Equipment coil reels are provided as standard in 6" width increments.

The 2,500# Series and 4,000# Series of coil reels are designed to provide a lifetime of reliable pay-off of primarily light and medium gauge coil stock material. These reels are typically matched with the ServoMaster Series 1 and 2 servo roll feeds and 250 Series power straighteners.

Extensive standard features are included in these coil reels. Heavy duty welded construction, three (3) pad mandrel construction, and manual hand crank expansion with a snapout handle are a few of the features that make these reels an excellent value in the market.

Extensive optional equipment can be selected to configure these reels to meet most application demands. Equipment such as double-ended configurations, full OD backplates, coil clockspring guards, and air-operated coil hold down arms can be provided to customize each machine.

Coe Press Equipment coil reels can be configured to work in a "pull-off" application with power straighteners and rollforming equipment, or they can be provided as "pay-off" reels with the drive mechanism to unwind the coil built into the machine. As with all reels built by Coe Press Equipment, necessary drive horsepower and torque are provided in our "pay-off" reels.

The 2,500# Series and 4,000# Series of coil reels are backed by our comprehensive "3-2-1" Warranty as well as our 24 Hour Technical Service program.



■ Standard 2,500# Series reel configured for "pull-off" application with manual hand crank expansion with a snapout handle, and a 30" diameter heavy duty backplate.



■ Standard 4,000# Series reel configured for a "pull-off" application with optional air operated coil hold down, manual hand crank expansion with a snapout handle, and a 30" diameter heavy duty backplate.



Standard Features

2,500# / 4,000# Series Reels

Pull-off Models

- Single-end Configuration
- Double-end Configuration
- Heavy Duty Welded Steel Construction
- "Bearing Tube" Support of Mandrel
- Manual Handcrank Expansion with Snapout Handle
- One Set of Three (3) Narrow Coil Keepers
- Three (3) Pad Mandrel Construction
- Heavy Duty Link Bar Type Expansion
- 16"-21" Mandrel Expansion Range
- 30" Diameter Heavy Duty Backplate
- 60" Maximum Coil Outside Diameter
- Air Disc Drag Brake to Prevent Coil Over Run

Motorized Models

- Standard 0-17 RPM Mandrel Rotation Speed - 80 FPM
- 1 HP AC Variable Speed Drive - 2,500# Series
- 2 HP AC Variable Speed Drive - 4,000# Series
- Digital AC Variable Speed Drive Control
- Potentiometer Control Variable Speed Loop Arm
- 230 / 460 Volt AC 3 Phase Incoming Power
- Standard Electrical Safety Disconnect

Optional Equipment

2,500# / 4,000# Series Reels

- Extra Set of Three (3) Narrow Coil Keepers
- Full O.D. Backplate for 60" Coil Diameter
- Provisions for 72" Coil Diameter
- Coil Width Scales on Mandrel Pads
- Heavy Duty Coil Clockspring Guard
- Coil Adapter Pads for Larger Coil ID's
- Air Operated Coil Hold Down Arm
- Remote Jog Pendant for Material Threading
- Ultra Sonic Variable Speed Loop Control
- Fail Safe Drag Brake Mechanism
- Larger HP Drive Packages for Higher Line Speeds



COIL REELS

■ 6,000# / 8,000# Series Reels

Coil Capacity	Minimum Width	Maximum Width
6,000#	18"	36"
8,000#	18"	36"

Coe Press Equipment coil reels are provided as standard in 6" width increments.

The 6,000# Series and 8,000# Series of coil reels are designed to provide a lifetime of reliable pay-off of primarily light and medium gauge coil stock material. These reels are typically matched with the ServoMaster Series 1 and 2 servo roll feeds and 250 Series power straighteners.

Extensive standard features are included in these coil reels. Heavy duty welded construction, three (3) pad mandrel construction, and manual hand crank expansion with a snapout handle are a few of the features that make these reels an excellent value in the market.

Extensive optional equipment can be selected to configure these reels to meet most application demands. Equipment such as double-ended configurations, full OD backplates, coil clockspring guards, and air-operated coil hold down arms can be provided to customize each machine.

Coe Press Equipment coil reels can be configured to work in a "pull-off" application with power straighteners and rollforming equipment, or they can be provided as "pay-off" reels with the drive mechanism to unwind the coil built into the machine. As with all reels built by Coe Press Equipment, necessary drive horsepower and torque are provided in our "pay-off" reels.

The 6,000# Series and 8,000# Series of coil reels are backed by our comprehensive "3-2-1" Warranty as well as our 24 Hour Technical Service program.



■ Standard 6,000# Series reel configured for "pull-off" application with manual hand crank expansion, optional air operated coil hold down arm with motorized end wheel, and coil clockspring guard.



■ Standard 8,000# Series reel configured for a motorized "pay-off" application with optional traveling coil car and extra set of quick-release coil keepers.



Standard Features

6,000# / 8,000# Series Reels

Pull-off Models

- Single-end Configuration
- Double-end Configuration
- Heavy Duty Welded Steel Construction
- "Bearing Tube" Support of Mandrel
- Manual Handcrank Expansion with Snapout Handle
- One Set of Three (3) Narrow Coil Keepers
- Three (3) Pad Mandrel Construction
- Heavy Duty Link Bar Type Expansion
- 16"-21" Mandrel Expansion Range
- 30" Diameter Heavy Duty Backplate
- 60" Maximum Coil Outside Diameter
- Air Disc Drag Brake to Prevent Coil Over Run

Motorized Models

- Standard 0-17 RPM Mandrel Rotation Speed - 80 FPM
- 2 HP AC Variable Speed Drive - 6,000# Series
- 3 HP AC Variable Speed Drive - 8,000# Series
- Digital AC Variable Speed Drive Control
- Potentiometer Control Variable Speed Loop Arm
- 230 / 460 Volt AC 3 Phase Incoming Power
- Standard Electrical Safety Disconnect

Optional Equipment

6,000# / 8,000# Series Reels

- Extra Set of Three (3) Narrow Coil Keepers
- Air Operated Narrow Coil Guide Assembly
- Full O.D. Backplate for 60" Coil Diameter
- Provisions for 72" Coil Diameter
- Coil Width Scales on Mandrel Pads
- Heavy Duty Coil Clockspring Guard
- Coil Adapter Pads for Larger Coil ID's
- Air Operated Coil Hold Down Arm
- Air Operated Hold Down with Motorized Endwheel
- Remote Jog Pendant for Material Threading
- Ultra Sonic Variable Speed Loop Control
- Hydraulic Threading Drive (Pull-off Models)
- Hydraulic Expansion Feature
- Hydraulic Traveling Coil Car
- Fail Safe Drag Brake Mechanism
- Power Mandrel Indexing - Double-end Models



COIL REELS

Features & Benefits

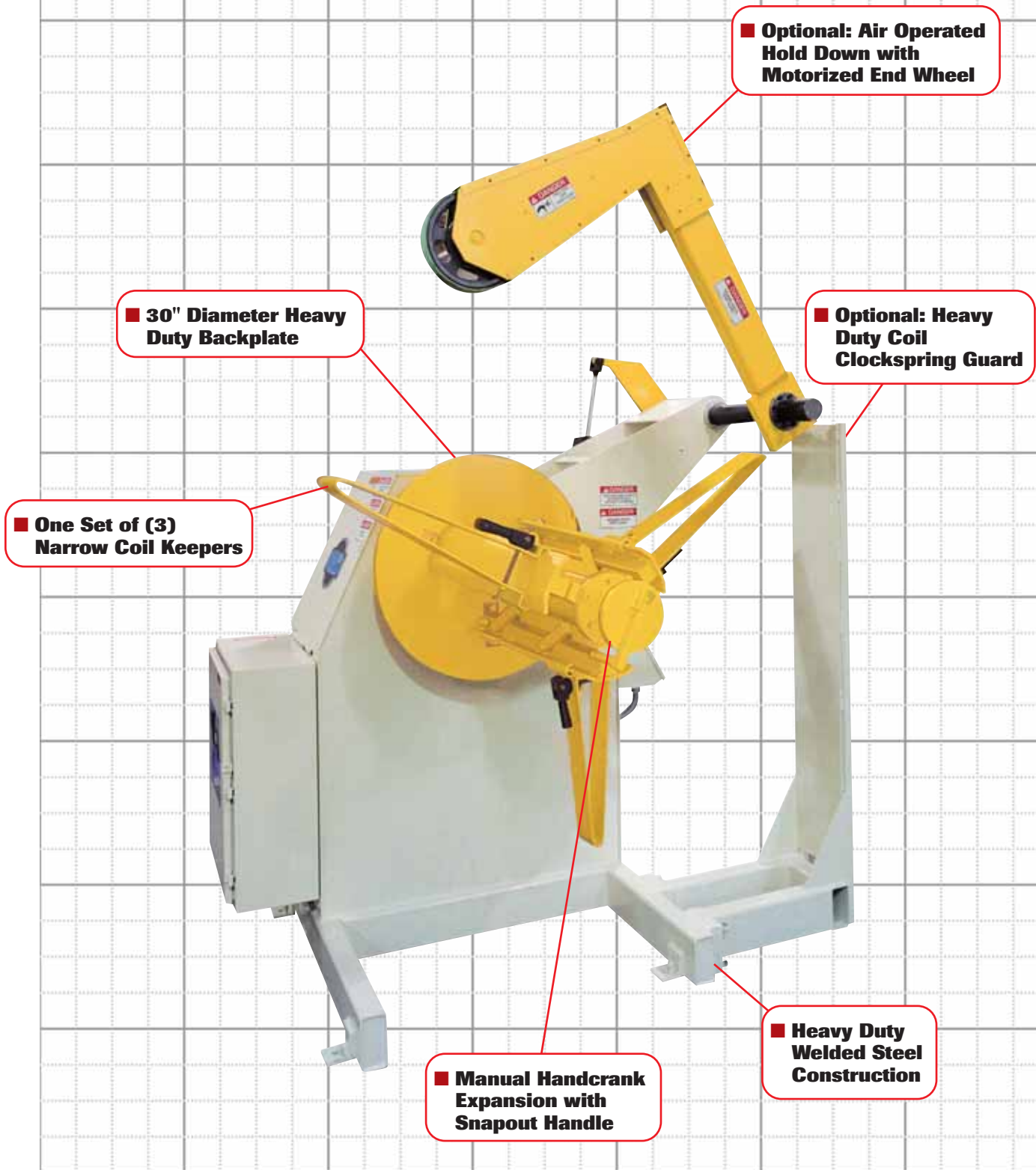



Double-End Configuration

■ **Optional: Air Operated
Coil Hold Down Arms**

■ **Optional: Hydraulic
Expansion Feature**

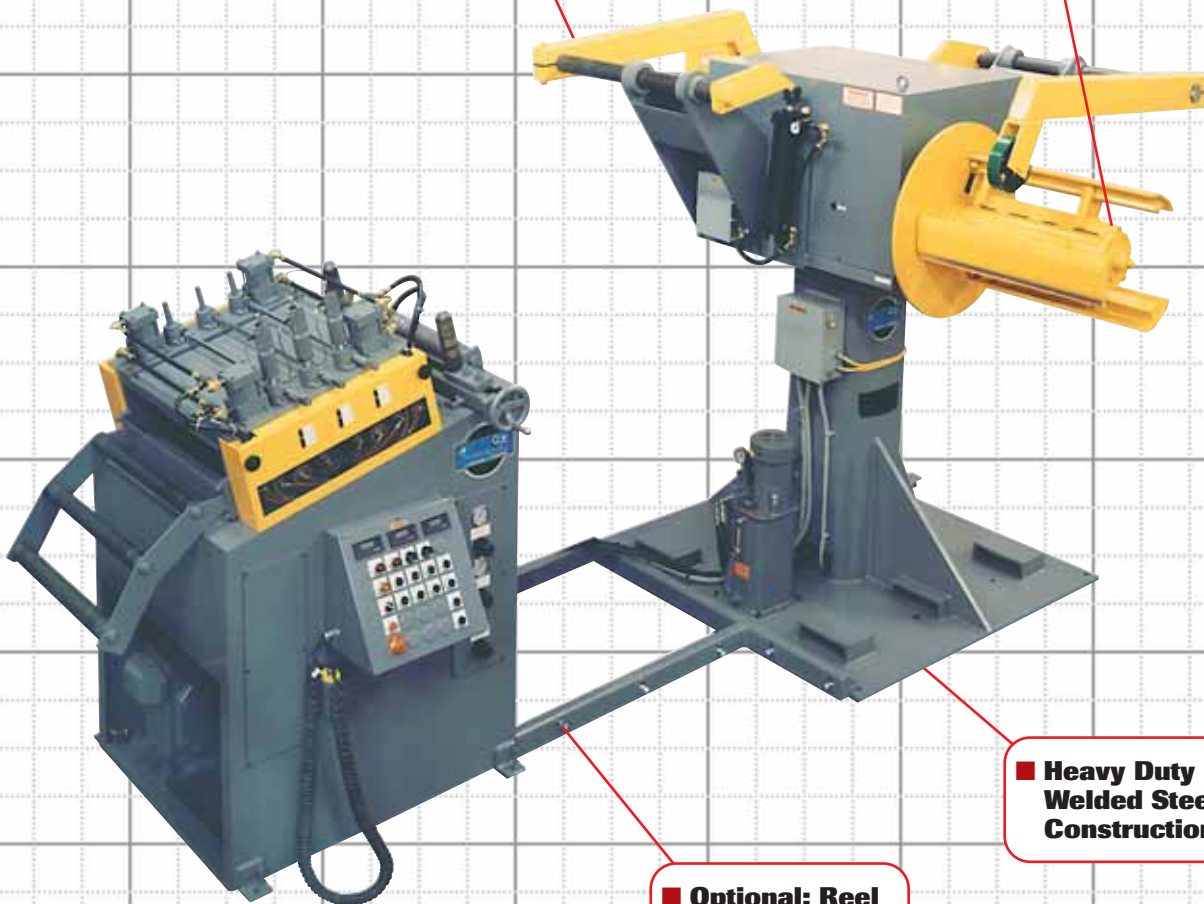

■ **Heavy Duty
Welded Steel
Construction**

■ **Optional: Reel
to Straightener
Tie in Brackets**

COIL REELS

■ **10,000# - 60,000# Series Reels**

Coil Capacity	Minimum Width	Maximum Width
10,000#	18"	60"
15,000#	18"	60"
20,000#	24"	72"
30,000#	24"	72"
40,000#	36"	72"
50,000#	36"	78"
60,000#	36"	78"

Coe Press Equipment coil reels are provided as standard in 6" width increments.

The 10,000# Series through 60,000# Series of coil reels are designed to provide a lifetime of reliable pay-off of primarily light, medium, and heavy gauge coil stock material. These reels can be matched with Coe Press Equipment servo roll feeds and power straighteners to provide full system capability for a wide range of material widths and coil weights.

Extensive standard features are included in these coil reels. Heavy duty welded construction, three (3) pad mandrel construction, hydraulic mandrel expansion, and in-built utilities are a few of the features that make these reels an excellent value in the market.

Extensive optional equipment can be selected to configure these reels to meet most application demands. Equipment such as double-ended configurations, full OD backplates, coil clockspring guards, and air-operated coil hold down arms can be provided to customize each machine.

Coe Press Equipment coil reels can be configured to work in a "pull-off" application with power straighteners and rollforming equipment, or they can be provided as "pay-off" reels with the drive mechanism to unwind the coil built into the machine. As with all reels built by Coe Press Equipment, necessary drive horsepower and torque are provided in our "pay-off" reels.

The 10,000# Series through 60,000# Series of coil reels are backed by our comprehensive "3-2-1" Warranty as well as our 24 Hour Technical Service program.



■ Standard 15,000# Series reel configured for a motorized "pay-off" application with optional coil hold down arm and motorized end wheel, an extra set of quick release keepers, and a traveling coil car.



■ Standard 60,000# Series reel configured for a "pull-off" application with optional traveling coil car and one set of heavy duty quick-release coil keepers.



Standard Features

10,000# - 60,000# Series Reels

Pull-off Models

- Single-end Configuration
- Double-end Configuration
- Heavy Duty Welded Steel Construction
- "Bearing Tube" Support of Mandrel
- Hydraulic Mandrel Expansion Feature
- Hydraulic Threading Drive Feature
- One Set of Three (3) Narrow Coil Keepers
- Quick Release Type Narrow Coil Keepers
- Three (3) Pad Mandrel Construction
- Coil Width Scales on Mandrel Pads
- Heavy Duty Link Type Expansion (10,000#)
- Heavy Duty Wedge Type Expansion (15,000# - 60,000#)
- 18.25"-22.75" Mandrel Expansion Range (10,000# - 20,000#)
- 20.25"-24.75" Mandrel Expansion Range (30,000# - 60,000#)
- 27" Diameter Heavy Duty Backplate
- 72" Maximum Coil Outside Diameter
- Hydraulic Mandrel Indexing - Double-end Models

Motorized Models

- Standard 0-17 RPM Mandrel Rotation Speed - 80 FPM
- 5 HP to 20 HP AC Variable Speed Drives
- HP Rating Dependent on Capacity and Speed
- Digital AC Variable Speed Drive Control
- Potentiometer Control Variable Speed Loop Arm
- 230 / 460 Volt AC 3 Phase Incoming Power
- Standard Electrical Safety Disconnect

Optional Equipment

10,000# - 60,000# Series Reels

- Extra Set of Three (3) Narrow Coil Keepers
- Full O.D. Backplate for 72" Coil Diameter
- Heavy Duty Coil Clockspring Guard
- Coil Adapter Pads for Larger Coil ID's
- 300° Full Radius Mandrel Pads
- Multiple Stage Air Disc Drag Brakes
- Fail Safe Brake Mechanism
- Air Operated Coil Hold Down Arm
- Air Operated Hold Down with Motorized Endwheel
- Remote Jog Pendant for Material Threading
- Ultra Sonic Variable Speed Loop Control
- Hydraulic Traveling Coil Car



COIL REELS

Features & Benefits

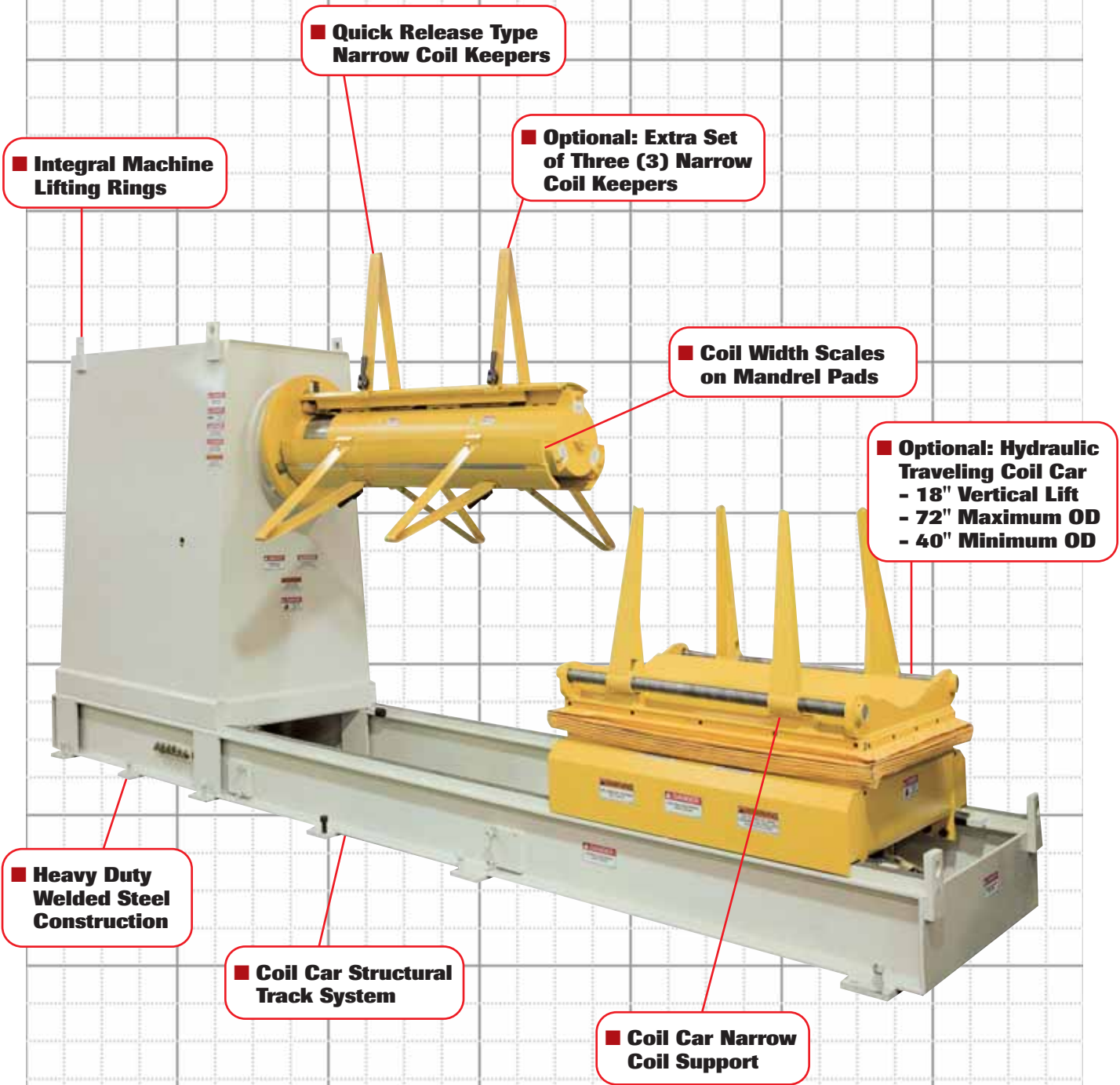

■ **Integral Machine Lifting Rings**

■ **Quick Release Type Narrow Coil Keepers**

■ **Optional: Extra Set of Three (3) Narrow Coil Keepers**

■ **Coil Width Scales on Mandrel Pads**

■ **Optional: Hydraulic Traveling Coil Car**
 - 18" Vertical Lift
 - 72" Maximum OD
 - 40" Minimum OD

■ **Heavy Duty Welded Steel Construction**

■ **Coil Car Structural Track System**

■ **Coil Car Narrow Coil Support**



Double-End Configuration

■ Quick Release Type Narrow Coil Keeper

■ Optional: Air Operated Hold Down with Motorized Endwheel

■ Optional: Hydraulic Traveling Coil Car

■ Optional: Reel to Straightener Tie in Brackets

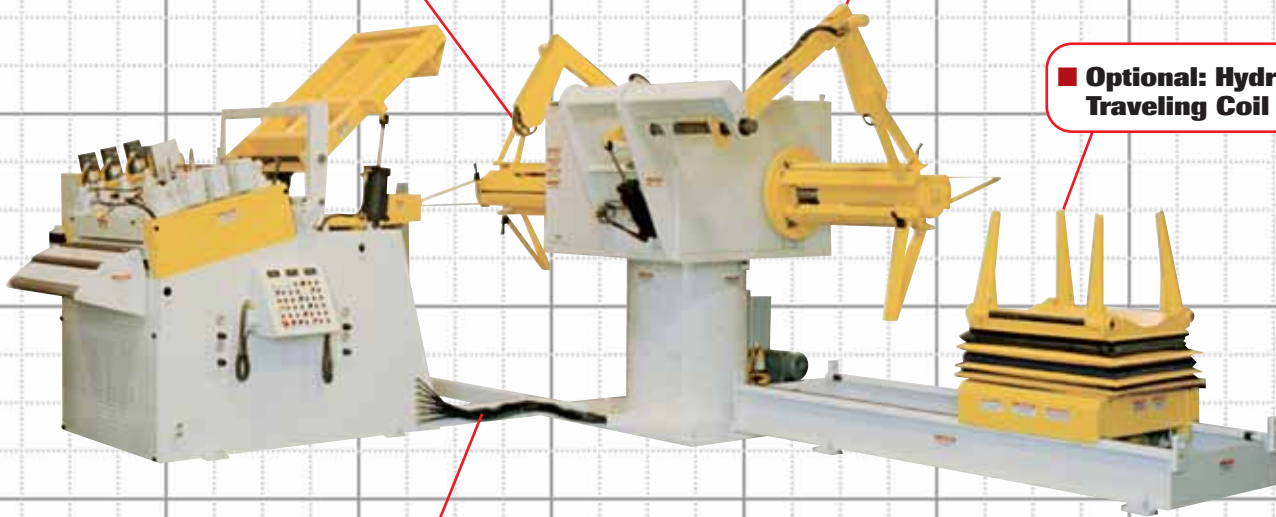

ADDITIONAL EQUIPMENT

COE PRESS EQUIPMENT CORPORATION

COMPLETE PRODUCT LINE

Fully Integrated Coil Feeding Lines

Coe Press Equipment designs and builds coil feeding lines to meet a wide variety of markets and application demands. Current applications include automotive, appliance, HVAC, lighting, housewares, service center, and others. We combine technologically advanced design and expert manufacturing techniques to produce fully integrated systems to efficiently unwind, straighten, and feed coil stock materials.



Individual Equipment

■ ServoMaster Series

The ServoMaster Series of servo roll feeds provides the highest capacity to feed coil stock material at the most competitive market prices. This family's feature rich and high performance machines are of modular construction of common components and share many manufacturing methods as the basis of their effective price structure. Starting with the Series 1 with 2.25" diameter rolls through the Series 4 with 4.0" diameter rolls, these feeds are capable of processing material from .010" to .310" in thickness. Machine widths from 6" to 54" are standard. Production rates up to 300 cycles per minute are obtainable. Standard equipment for the ServoMaster Series includes: AC brushless servo motors, a closed loop positioning system, low inertia drive system with sheaves and non-stretch Kevlar timing belt, precision cluster gear driven upper roller, accuracy of +/- .003", true pivoting upper feed roll for pilot operation, adjustable stroke cylinder with single point pilot stroke adjustment, adjustable radius catenary section, ergonomic slant-top control console, and the user-friendly ServoMaster Controller.



■ Servo Roll Feeds

Coe Press Equipment Corporation combines intelligent design, high quality components, and precision assembly to produce a full range of dependable and versatile servo roll feeds. Roll feed widths from 12" through 84" and feed roll sizes from 5.0" diameter through 8.0" are standard. Material thickness ranges from .010" to .625" can be processed. Standard features and benefits included on all servo feeds include: AC brushless servo motors, closed loop servo system, aluminum alloy pulley and non-stretch Kevlar timing belt drive, cluster gear drive of upper roller, accuracy of +/- .003", heavy duty fabricated cabinet, adjustable feed height, self-centering material edge guides, adjustable stroke pilot release mechanism, and catenary material support rollers. Coe Press Equipment Corporation offers a full range of standard equipment available with a variety of options to meet any customer's application.

■ Air Feeds

The air feed is a cost effective entry level feeding system offered in a full range of sizes and capacities. Starting with the CF200 with a 2" diameter air feed cylinder through CF600 with a 6" diameter air feed cylinder this product can provide the driving force to meet any application needs. Wide and heavy material applications utilize a double-feed head for gripping and feeding the coil stock. Standard features and benefits on this equipment include: hand crank stroke adjustment, heavy duty guide bars, high strength aluminum gripper assembly, and press interface controls. Available option equipment includes: "Air Saver" cylinders, pull-through straighteners, powered threading rolls, remote jog control, stroke length indicators, and heavy-duty cabinet bases. The air feed equipment can be designed for special feeding applications including: wire feeding, tube feeding, push-pull applications, dual strip applications, and zig-zag applications.



■ Power Straighteners

The full line of power straightener equipment can process material at widths from 3.0" to 84.0" and thickness from .010" to .625". The correct design of breaker roll diameter and center distance spacing provides effective removal of coil set for all material types and size combinations. Breaker roll sizes from 2.25" to 6.00" are available with the capability of providing roller "back-ups" for low deflection applications. Standard features and benefits on this equipment include: heavy duty fabricated base, seven (7) breaker rolls, close tolerance cluster gear drive train, independent height adjustment of breaker rolls, entrance side pinch rolls, exit side pinch rolls, DC or AC variable speed drive, material edge guide system, loop control system, and peeler / threader / hold down devices for "hands-free" material threading. A wide variety of options and custom engineering can be provided to meet any application demands.



40549 Brentwood
Sterling Heights, MI 48310
(810) 979-4400 • Fax (810) 979-2970
Website: www.cpec.com



Coe Press Equipment Corporation
"The Company That Feeds an Industry"